



**BT PANEL
MACHINE SAFETY
FENCE
INSTALLATION
AND
MAINTENANCE
MANUAL**



CONTENTS

| | |
|---|---|
| 1. PRODUCT INFORMATION..... | 2 |
| 1.1 DEFINITION..... | 2 |
| 1.2 FIELDS OF APPLICATION..... | 2 |
| 1.3 STANDARD DIMENSIONS..... | 3 |
| 2. INSTALLATION – DISMANTLING – TRANSPORT | 4 |
| 2.1 BEFORE BEGINNING THE WORK..... | 4 |
| 2.2 INSTALLATION..... | 5 |
| 2.3 DISMANTLING..... | 7 |
| 2.4 TRANSPORT | 7 |
| 3. OPERATION..... | 7 |
| 4. MAINTENANCE | 8 |
| 5. SAFETY..... | 8 |
| 6. IMPORTANT WARNINGS..... | 8 |

1. PRODUCT INFORMATION

1.1 DEFINITION

BT-Panel Machine Safety Fence is a system in which unframed safety panels are mounted between posts fixed to the ground at regular intervals. It is installed at safety distances and heights dimensioned in compliance with ISO 13857.

It is the essential element for improving machine safety by providing a physical safety barrier around it, limiting the access of the staff to the machine.



CAUTION: The product should not be used in places and conditions unsuitable for its purpose.

1.2 FIELDS OF APPLICATION

The product is a complementary component of guarding systems for perimeter safety. It is a physical safety item used for fencing in machinery or material located inside a designated area in larger workspaces.

Machine safety fence systems are used for increasing safety by limiting access of staff near all kinds of equipment which could be dangerous for humans, like automatic or semi-automatic machines with mechanical actions, robotic cells, cells containing extremely hot or cold processes, etc.

1.3 STANDARD DIMENSIONS

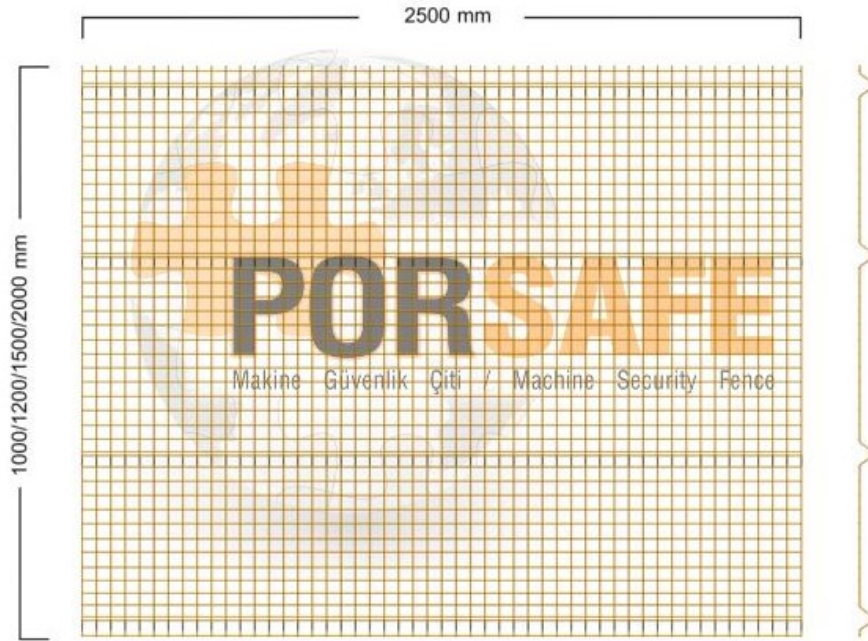

PANEL DIMENSIONS

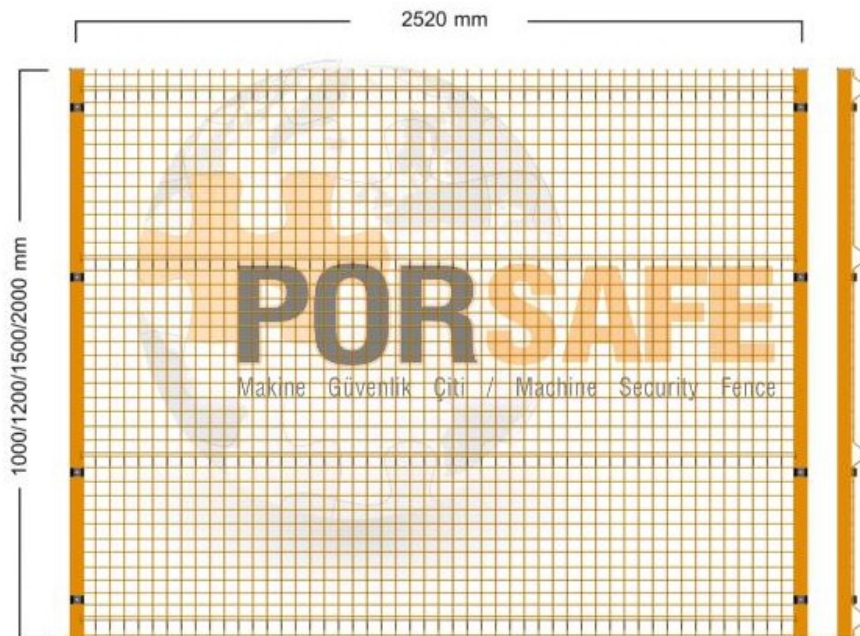

SYSTEM DIMENSIONS

2. INSTALLATION – DISMANTLING – TRANSPORT

2.1 BEFORE BEGINNING THE WORK

- Use **personal protective gear** (barrette, steel toe shoes, gloves, goggles etc.)



- Take precautions to **limit the entrance to the workspace.**



- Use only **appropriate equipment and tools.**

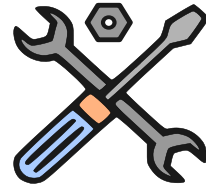

2.2 INSTALLATION

1. Place the posts where they are supposed to be located, drill 4 holes on the ground through the holes of the post bases.
2. Fix the post on the ground by 4 size expansion bolts of size M10*90 and level the post.

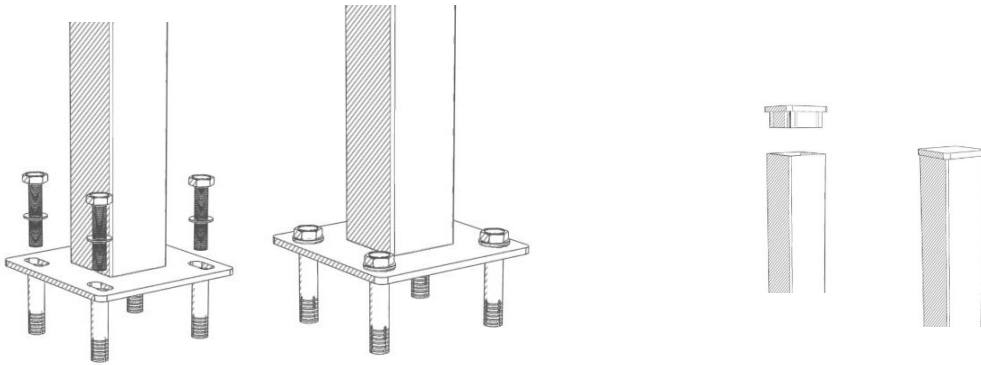

3. Place the post cover.
4. Place the BT Panel on the outer side of the posts, drill a hole on the post and fix the panel to the post using the clips and self-tapping screw. Use 4 clips for 2,00m posts; 3 clips for 1,50m and 1,20m posts. Make sure to place the clips right under and over horizontal wires of the panel, to prevent the panel from sliding or down.

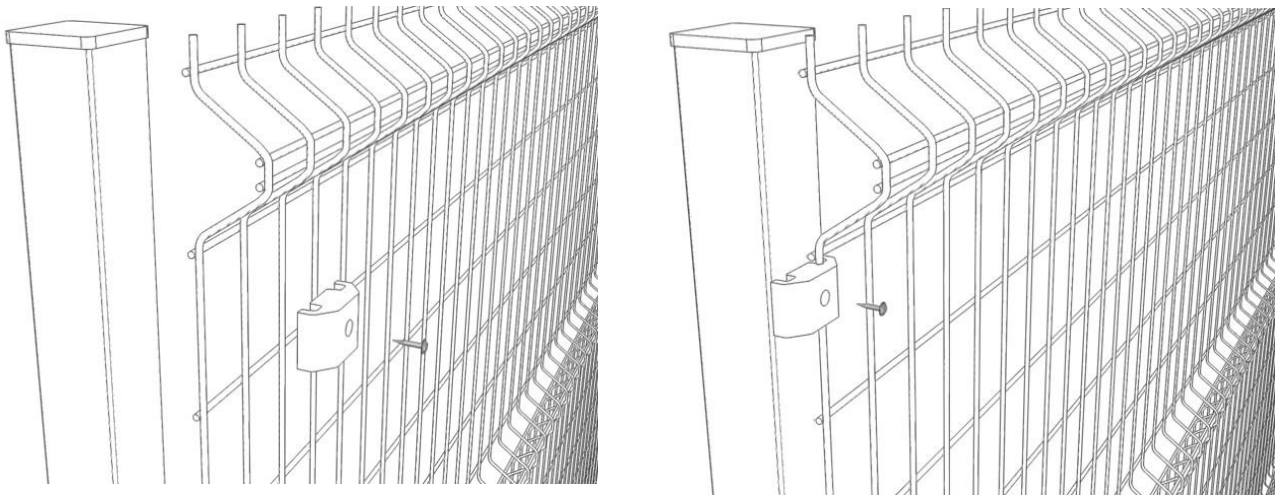

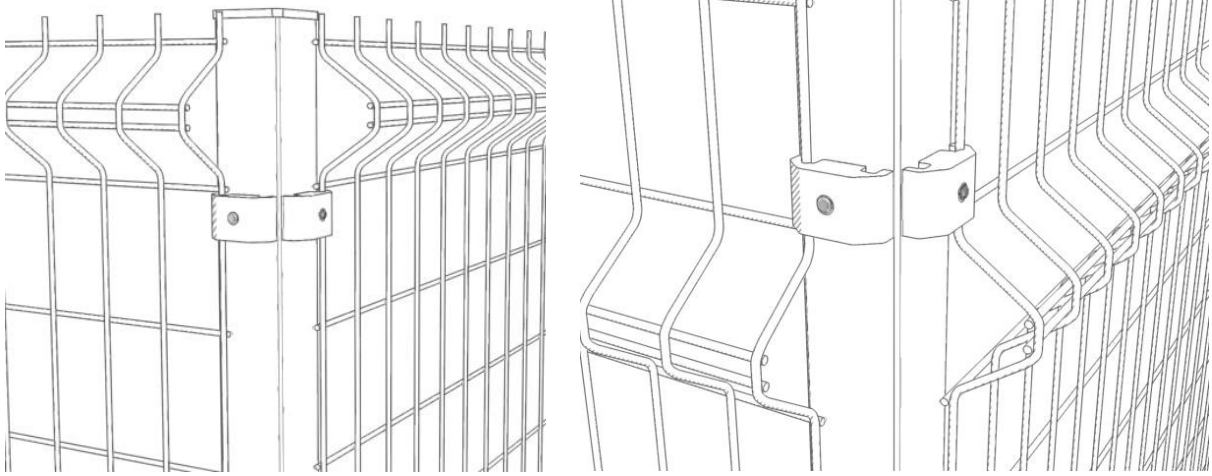

5. Mount all BT Panels on the posts.
6. Make the final visual and manual inspection. Finish the installation work by removing the equipment and tools from the work area.



2.3 DISMANTLING

1. Dismantling is done through the steps described above, in reverse order.
2. Group the dismantled pieces, rack and place them properly on a pallet, to ensure safe transport.

2.4 TRANSPORT

1. Depending on the conditions and resources available, transportation can be done by a fork-lift, pallet truck, or piece by piece by hand.
2. Sharp edges of the pieces must be covered with protective material.
3. Proper precautions must be taken against the risk of sliding or tipping over of racked material.

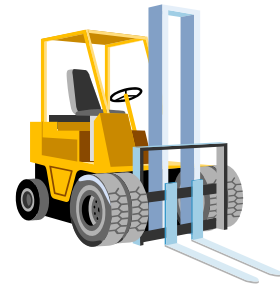

3. OPERATION

Machine safety fence system is a structure for limiting access to the encircled area to provide human and machine safety, as the name indicates.

Signs and symbols relevant to this purpose must be placed and the staff must operate according to these warnings.

Operators who must enter within the safety area must be qualified and authorized.

The doors must be operated as specified and there must be no obstructions during opening.

It is the operator's responsibility to provide the above-mentioned conditions and take additional necessary precautions.



4. MAINTENANCE

Hinge and ground fixations must be checked visually and manually, periodically.

Maintenance is necessary to sustain the functionality of the protective system and keep it in operating conditions.

Routine maintenance must be done every 3 months, with the exception of urgent cases.

5. SAFETY

Authorized staff must handle installation, dismantling and transport of the safety fence system.

Safety zone encircled by the safety fence system must be well illuminated, warning signs relevant to the safety zone must be placed and authorized staff must be informed.

Warning signs must be placed around the safety fence to prevent forklift, crane or other transport vehicles to hit and damage the fence; other staff working close to the fence system must be warned and informed.

6. IMPORTANT WARNINGS

- The product should not be used in places and conditions unsuitable for its purpose.
- If the door is used in the safety fence of machinery with risk of danger, precautions must be taken as specified in ISO 14120, ISO 12100 standards.
- Any locks or other equipment with start/stop functions which are not supplied in our product package must be applied following the ISO 12100 standard.
- In cases of dangerous levels of electrostatic charge or risk of electric leakage from machinery and equipment, ISO 12100 standards must be strictly observed.



- Layout plan of the products in the workspace must comply with ISO 13857 safety distances standards.
- Use warning signs for the application.
- If it is needed to access the dangerous zone when the machinery within the safety zone are in operation, take precautions as given in ISO 12100.
- Proper warnings and precautions must be in place to prevent access and interference of unauthorized staff to the safety zone.